

Chapter 4

Section 2 - Vertical Tail

Material:

4-40 x 1/4" button head screws - 8

Hangar 9 servo arms - 4

Dubro 1/4 scale hinges - 1pkg

.047" Piano wire - 1

Nyrod - 6"

Parts:

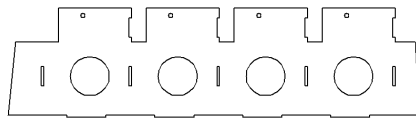

Servo Case Right Plate - 1
1/16" ply

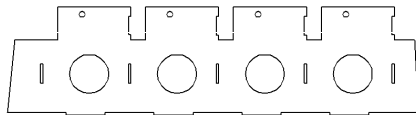

Servo Case Left Plate - 1
1/16" ply



Fuselage F10 Former - 1
1/16" ply



Servo Case Sides - 4
1/16" ply



Servo Case Top - 1
1/16" ply



Rudder Horn - 4
1/16" ply

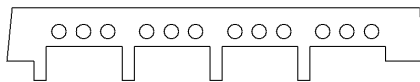

Rudder Horn Plate - 2
1/16" ply

Vertical Stabilizer

- Lay the vertical tail plan out on the table and cover with wax paper.
- Pin the hinge post to the plan. It is important to exactly position the lower edge of the post according to the plan.
- Loosely position all parts for the vertical stab on the plan. When satisfied with the positioning, pin in place
- Add thin CA to all of the joints.

Rudder

- Screw Hangar 9 servo arms to each of the 4 servo horns. Use 2, 4-40 x 1/4" bolts per horn and finish with a little thin CA to bond the assembly together.
- Pin the hinge post to the plan. Pay careful attention to the lower edge placement. The post is located .047" behind the vertical stab hinge post - the thickness of a hinge pin.
- String the 4 servo horns on a length of piano wire, making sure to get the splines oriented downward. This wire will be used to align the servo arms with the rudder hinge line - which is absolutely critical.
- Pin the horn spacers to the plan, with the horns between them. Adjust these parts so the piano wire is located on the hinge line, and that it passes perfectly through the center of the servo arms.
- When happy with the alignment, bond the horns to the spacers by applying thin CA to the joints.
- Finish loosely placing the remainder of the rudder balsa parts. When satisfied with the fit, pin all parts in place.
- Add thin CA to all of the joints.

Servo Case

- Install 4-40 blind nuts into the left side of the rudder servo case plate. Be sure to install them on the proper side of the plate. Lock them in place with scraps of glass cloth and thin CA.
- Assemble the rudder servo case using thin CA.

Rudder Servo Case Assembly

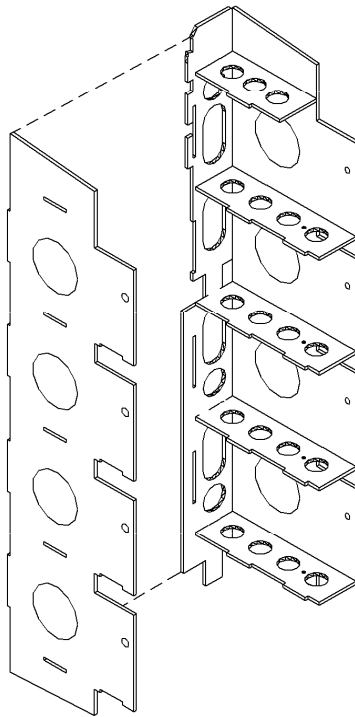

- Glue the left horn plate in position on the rudder. The tabs that interlock with the servo plate must be exactly located according to the plan.
- Remove the vertical stab and rudder from the table. Add thin CA around all of the joints.
- Lightly sand the area around the servo horns that was against the table.
- Glue the remaining horn plate onto the right side of the rudder.

- Mark and slot the hinge posts for hinges.
- Install the hinges, making sure to align the rudder and vertical stab exactly according to the plan.
- Drill a 1/8" hole through the top of the rudder, to allow the hinge pin to be installed through the rudder leading edge.
- Carefully align and glue the nyrod into the hole so the hinge pin can be inserted into the hinges.

Finishing

Note: The following procedure requires a table saw with a 1/8" blade. It must be accomplished with extreme caution, as you will be working in close proximity to a large section of the saw blade.

- Cut a 1/8" slot, 2" deep into the trailing edge of the rudder.
- Slide the rudder trailing edge reinforcement into the slot you just cut in the rudder. Glue it in place while pressing the trailing edge firmly against the table to keep the trailing edge straight.
- Bevel the horn plates as necessary so the rudder moves freely throughout its range of travel.
- Sand the vertical tail to shape:
 1. Round the leading edge of the vertical stabilizer and rudder.
 2. Taper the trailing edge of the rudder. It will be full thickness at the hinge line, and the thickness of the reinforcement at the trailing edges.
 3. Round the bottom of the Rudder.
 4. Put a very small radius on the top of the rudder.